



Heritage

Jupiter 3

INSTRUCTION MANUAL



CONTENTS

Introduction	3
Measurements & Useful Info.....	4
Seating System Components	5
Important Safety Advice	6
Important - Lap Strap Safety	7
Push Handle Attachment / Removal.....	8
Adjusting Tilt / Prone (Electric Chair)	9
Applying / Releasing Brakes	9
Footplate Positioning.....	10
Chair Height Adjustment	11
Head Rest Adjustment / Replacement	12
Altering Upper Back Support.....	13
Neck Rest Use	13
Back Height Adjustment	14
Arm Rest Adjustment / Seat Width.....	14
Seat Depth Adjustment	15
Cleaning & Care.....	16
General Maintenance	16
Servicing via Approved Repairer.....	17
Service / Maintenance Record Log.....	18
Warranty	19
Inspecting & Reissuing of Equipment.....	20

Introduction

The **Jupiter 3** is designed to provide specialised comfort and postural support for adults.

This instruction manual contains very important information about the **Jupiter 3** seating system, how to use it safely and obtain the best results from it. Please read all the information contained in this manual before using the chair and retain for future reference. Ensure everyone using the equipment is aware of the contents of this manual and understands how to use the equipment safely.

These instructions provide guidance on the adjustments for professionals, but they also give information on how the equipment should be safely used, maintained, checked, and correctly assembled by anyone who uses the seating system.

In every case the equipment should be supplied via qualified professionals who will have adjusted the equipment, checked its compliance and tested it appropriately.

The seating system should only ever be adjusted by qualified professionals and persons that are suitably trained. For further information please do not hesitate to contact us - all contact details are on the back cover of the manual.

Thank you for purchasing our product, we hope you enjoy your new seating system.

Measurements & Useful Info

MEASUREMENTS (cm)	Jupiter 3	
	MIN	MAX
A Back Height	66	81
B Seat Depth	40	52
C Top of Seat to Floor	52.5	60
D Seat Width	35	50
E Chair Footprint (Overall Length x Width)	66.5	70

Recline from vertical to 32°. Tilt from horizontal to 25° back. All dimensions are nominal.

The maximum loading on an **Jupiter 3** chair should not exceed 100kgs.

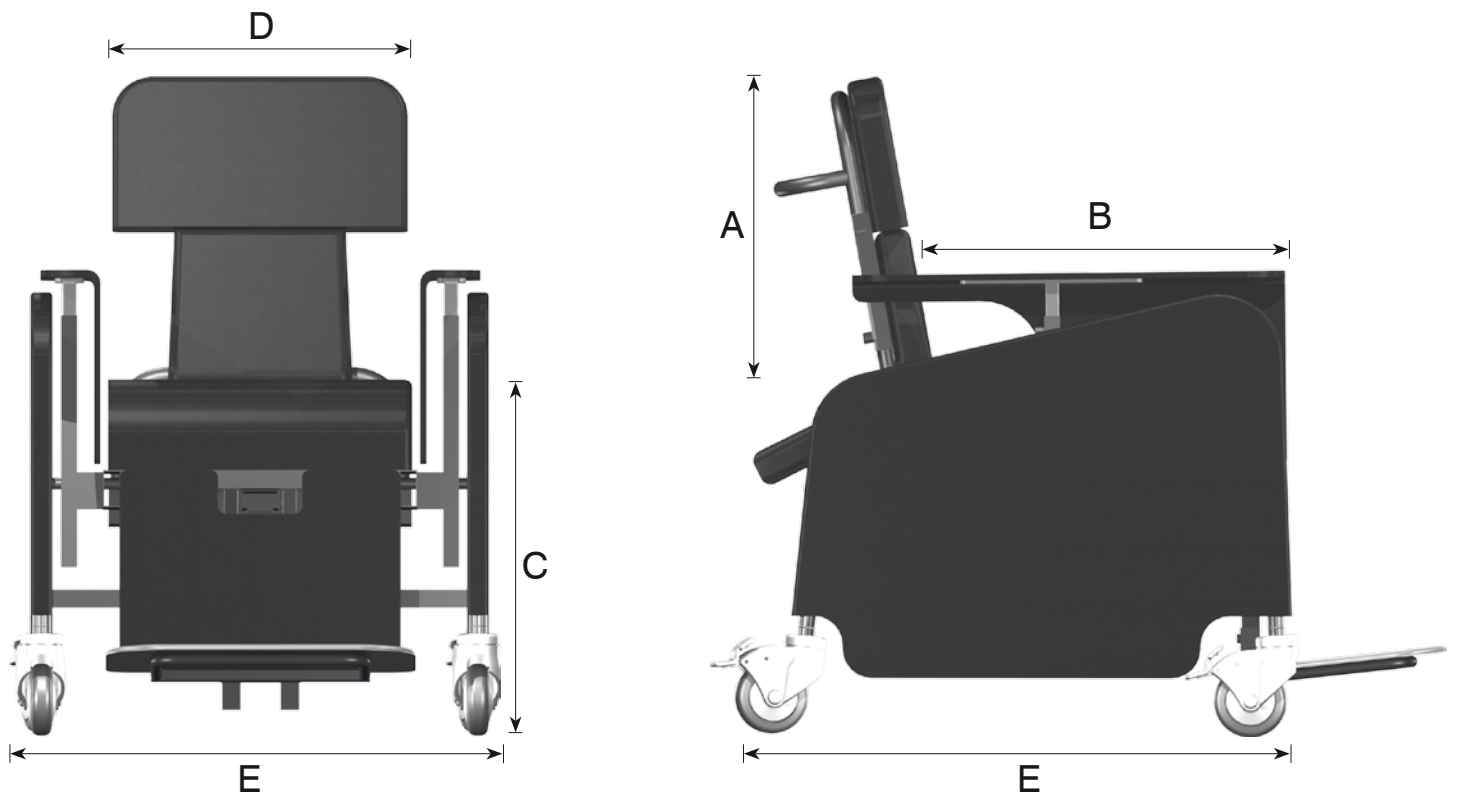

Electric Chair & Battery Pack

The electric version is supplied with a battery pack which allows the chair to be used without being plugged into the mains, preserving the chairs mobility.

When the power of the adjustments begins to weaken it is a sign that the **Jupiter 3** battery pack needs re-charging. To do this simply plug the chair into the mains and leave to charge fully (this takes approximately 2 hours).

Seating System Components

- A Push Handle
- B Neckrest
- C Upper Backrest
- D Lower Back Support Cushion
- E Seat Cushion
- F Padded Leg Rest
- G Locking Castors
- H Side Frame
- I Adjustable Arm Rest

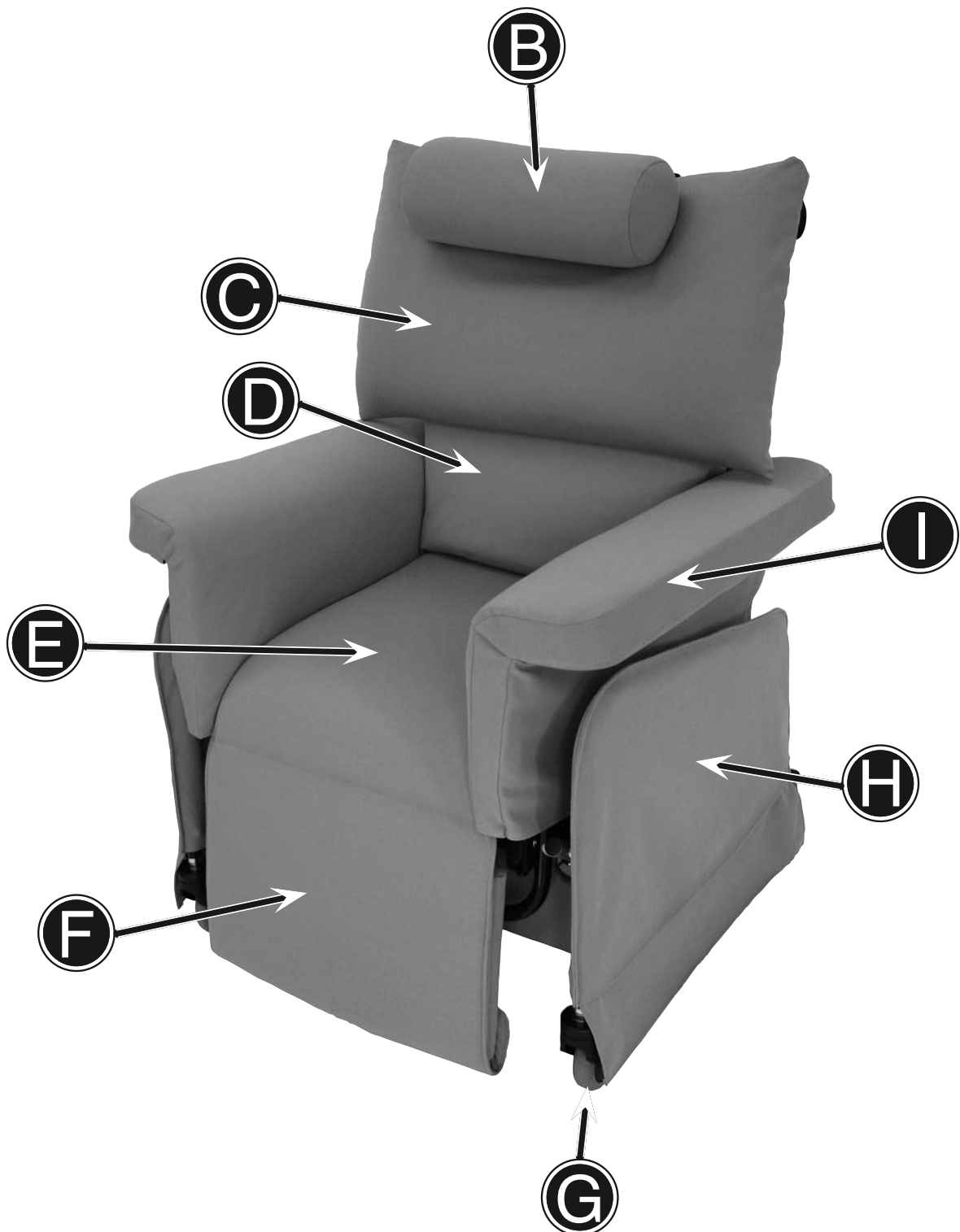

Important Safety Advice



We at Heritage are committed to producing products of the highest standard. All of our products fulfil the essential safety and environmental requirements as defined in the European Directives. However, improper use of the products will potentially put the users at risk and therefore Heritage strongly suggest that the following information is strictly adhered to at all times.

Throughout the manual there are important points to note identified by the symbol:



- The electric version of the Jupiter 3 chair should only be used with a 230 volt mains supply.
- Ensure all adjustment mechanisms are secure and in place before operation. If it is likely that the hand-wheels will be repeatedly loosened, Heritage can supply allen key bolts as an alternative. We strongly recommend this if there is a danger from those in the vicinity of the user.
- All postural support straps and harnesses should be in place and properly adjusted to the user, prior to usage of any kind (see page 7).
- Whilst the seating system is stable on a 5-degree slope, even in its most upright position, it is not intended to be used in this manner. It is however, intended to be used on a level flat floor, where movement is confined to a single room. For safety ALWAYS return the product to a neutral position before moving (lower in height, level the seat, ensure the back is upright etc).
- Heavy items on the tray will affect stability. The fitting of anything other than the standard Heritage tray may substantially affect the stability of the seating system and should therefore be checked for compatibility before issue.
- If at any time it is noted that areas of the users skin remain reddened after being out of the seating system for around 10 minutes, urgently contact the qualified professional who performed the hand over of the equipment. This may be a sign of excessive pressure being exerted by the seating. This might occur in the initial use of a new seat where further adjustment may be required, where the user has been badly placed, grown or where an underlying medical problem exists. Review may be necessary in such cases
- After completing any alterations ENSURE all nuts, bolts, knobs, hand wheels and other fixings are securely tightened and in position, and that they are regularly checked as part of the maintenance of the chair. Never over adjust or over tighten moving parts.
- Keep all products away from excessive sources of heat, cigarettes and naked flames.
- If you suspect that the system may be faulty, cease use of the equipment straight away and immediately contact the organization who supplied the system. (Heritages contact information can be found on the back cover).
- The equipment will be labelled with important information. NEVER REMOVE these information labels or allow them to be defaced, overlaid or altered.
- All modifications, adjustments, reconditioning, repairs, disposal, and servicing of the seating unit must ONLY be carried out by the agencies who supplied the equipment (see pages 14-15).

Accessories

Multi Adjustable Head support

Wings on the head support are ideally set at 45 degrees. Do NOT bring the wings in tight to the head. Ensure that the head support is set in such away that the child cannot loop their head around the wings and get stuck.

Flexi-Supports and Lateral Supports

Ensure the straps do not infringe on any feeding tubes the child may have.

Tray

Do NOT use the tray as a way of securing children in a chair always ensure that the lap strap and any other straps supplied are used. Ensure that the tray clips are secure on both sides of the tray. If the tray is damaged, ensure that this will not be a hazard to the user. Never leave hot items on the tray while children are unattended.

Important - Lap Strap Safety



Incorrect fitting of lap straps can put the user at serious risk. When using lap straps we recommend the following points should always be adhered to:

- Lap straps must always be fitted at 45 degrees to the pelvis of the user.
- Always check that the child's pelvis is symmetrical and positioned securely at the back of the seat.
- Always ensure that the lap straps and chest harness hold the child securely and are comfortable. Ensure they provide a snug fit, a simple rule of thumb is to allow two fingers to be inserted between the belt and the child's body.
- Never leave a child in a chair unattended without the lap strap being fastened.
- A lap strap should always be fitted if a harness is being used.
- When altering the angle between the seat and the back of the chair always re-adjust the chest harness and lap strap accordingly to ensure all safety recommendations are followed.

Harness and Lap Strap Positioning

This diagram shows the recommended positioning of the chest harness and lap straps:

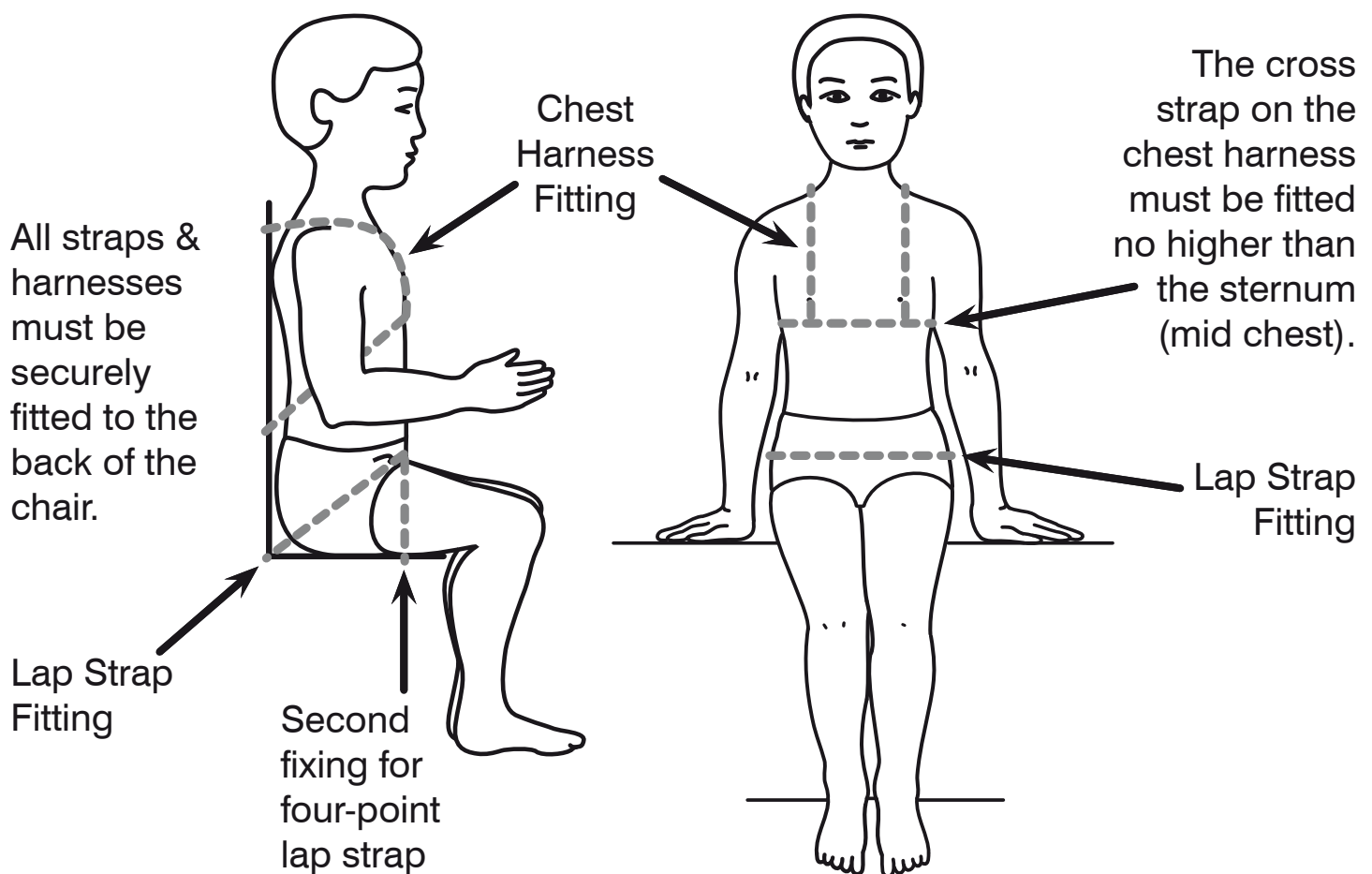

Points listed here are generic across the Heritage range and do not apply to all products.

Push Handle Attachment / Removal

The Jupiter 3 chair has a large, comfortable push handle which makes it easy to manoeuvre the chair.

The quick release feature makes mount and removal of the handle effortless.



Handle Removal

- Pull out plunger (B) to maximum tension and turn it through a half turn anti-clockwise. This places it in an open position.
- While supporting the back, slide the push handle up and off.

Handle Attachment

- Slot the push handle down into the brackets (A) on the back of the chair.
- Line up the hole on the push handle (C) with plunger (B).
- Turn plunger (B) a half turn clockwise and it should snap into a locked position to secure the handle into position.

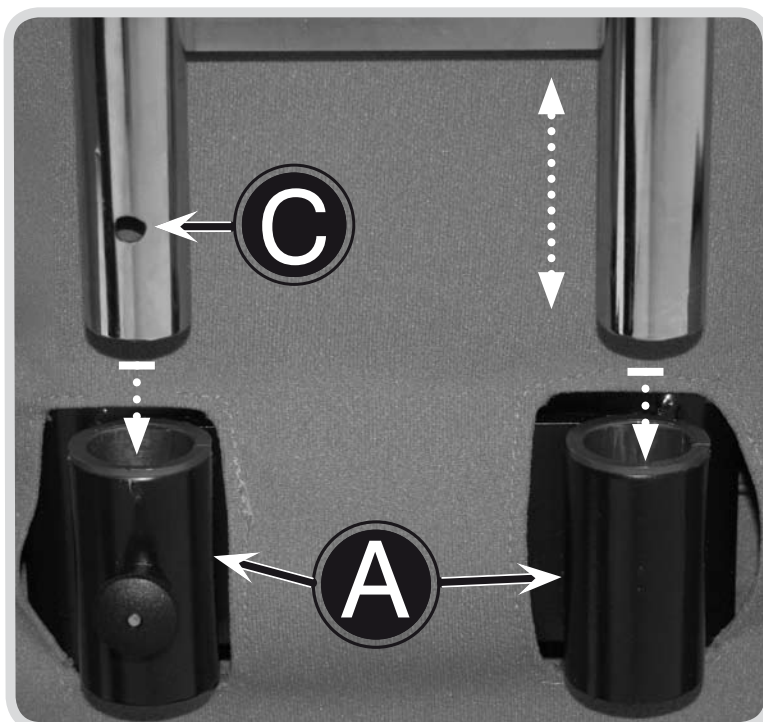

Adjusting Tilt / Prone (Electric Chair)

Pressing and holding down the appropriate button executes the following commands:

Button A - Left

Alters the seat tilt in space into recline.

Button A - Right

Alters the seat tilt in space into prone.

Button B - Left

Alters the back rest angle forwards.

Button B - Right

Alters the back rest angle backwards.

Button B&C - Left

Alters the back rest & leg rest together forwards (prone).

Button B&C - Right

Alters the back rest & leg rest together backwards (recline).

Button C - Left

Alters the leg rest down.

Button C - Right

Alters the leg rest up.



Always ensure that the adjustment mechanism is free from obstruction before operating this chair.

Applying / Releasing Brakes

Applying Brakes

Depress lever (B) with your foot. To secure the chair in place you should suppress all the brakes fitted to the wheels on the base.

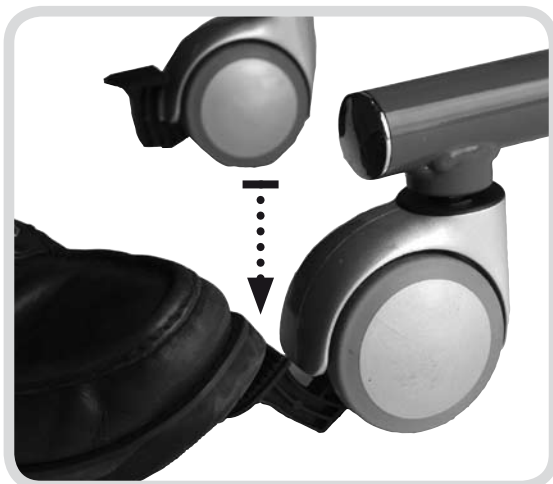

Releasing Brakes

To release the brakes you should flick the levers up using the top of your foot. When all brakes are released the chair will be free to travel in any direction.

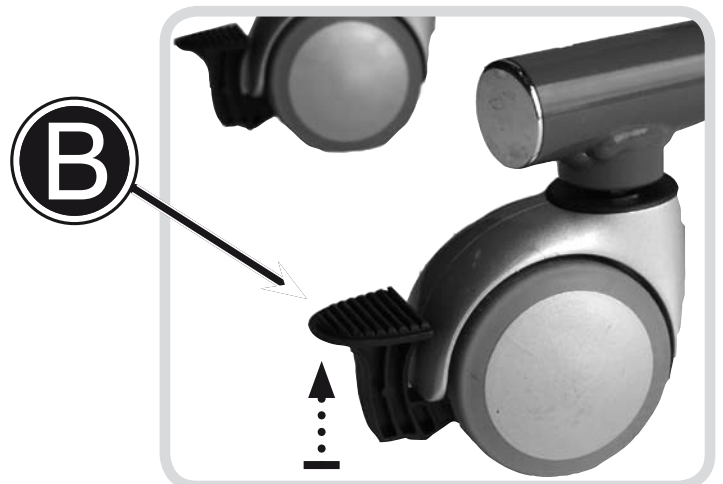

Footplate Positioning

Footplate Height

- Pull and hold out plunger (A).
- Adjust the footplate to suit the user and

provide suitable support and comfort.

- Re-locate the plunger onto one of the holes at the back of the plate (B) to secure into place.

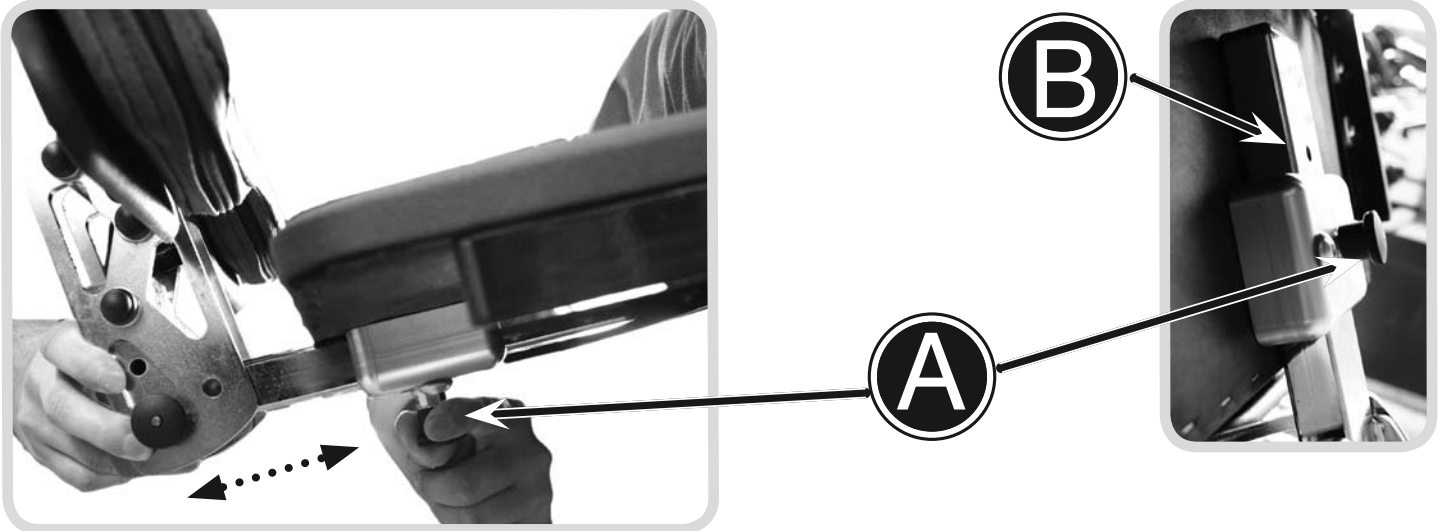

Footplate Angle

The footplate can be flipped out of the way by pushing it up towards the frame.

- Pull out both plungers (C)

- Manually adjust the footplate angle
- Release plungers (C) ensuring the footplate is securely re-located in place.

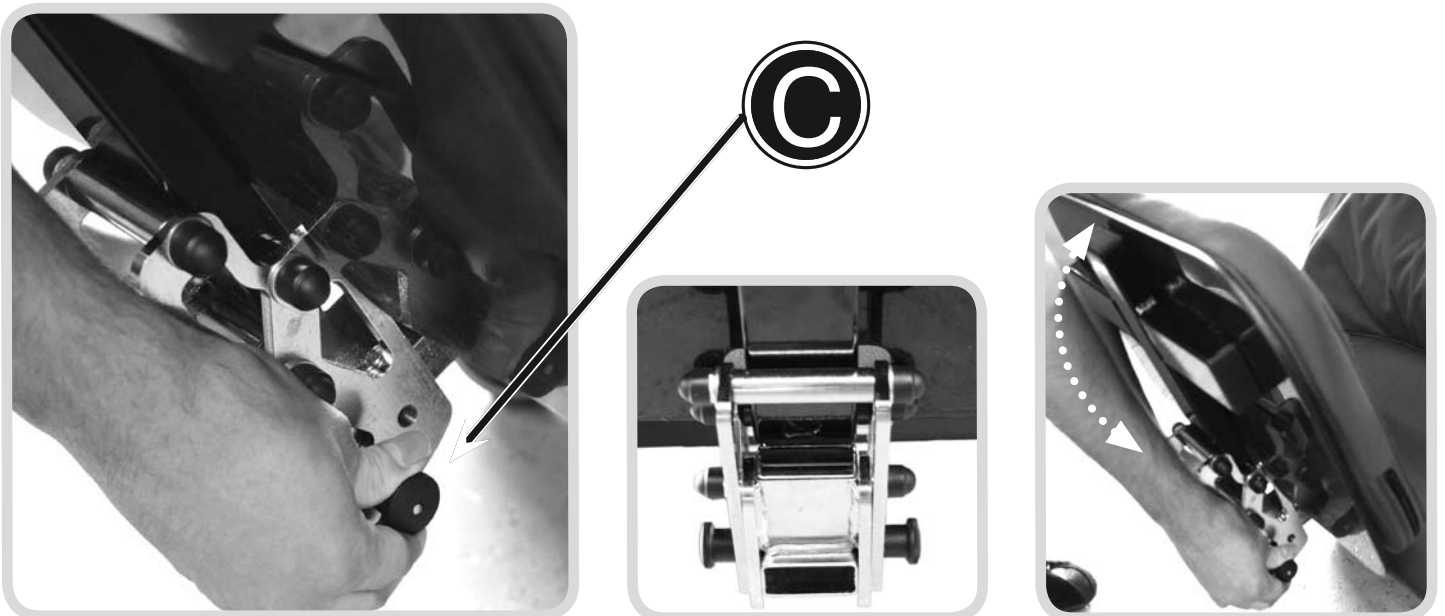

When a footplate is fitted to your chair you need to ensure that the height of the chair is set so that the footplate clears the ground in all positions.

Chair Height Adjustment



A



The height of the chair can be adjusted by removing pin (A) from the chair leg and pulling the castor away from the frame. This will reveal extra holes in the chrome work (B), which enable the chair to sit at different heights.

When a suitable height has been achieved re-align the relevant hole and re-insert the pin to lock the chair into place. The ring (C) should be fed through the hole in the pin to stop the pin from working loose from the frame.

Repeat this process for all four legs. Always ensure that all four legs are located identically and that the chair is level.

Replacement castors can be purchased from JCM if necessary.



C



Head Rest Adjustment / Replacement

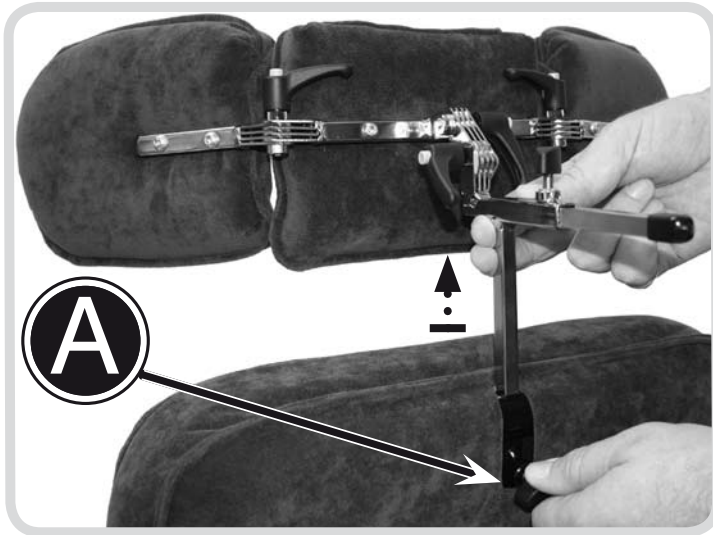

Head Support Height / Replacement

- Turning lever (A) anti-clockwise enables you to adjust the height of the head support by pulling it up or down. Re-tighten the lever to secure into place.
- (The headrest can be removed from the frame in this way if necessary by pulling up and out (B). A range of alternative Heritage headrests can be supplied.)

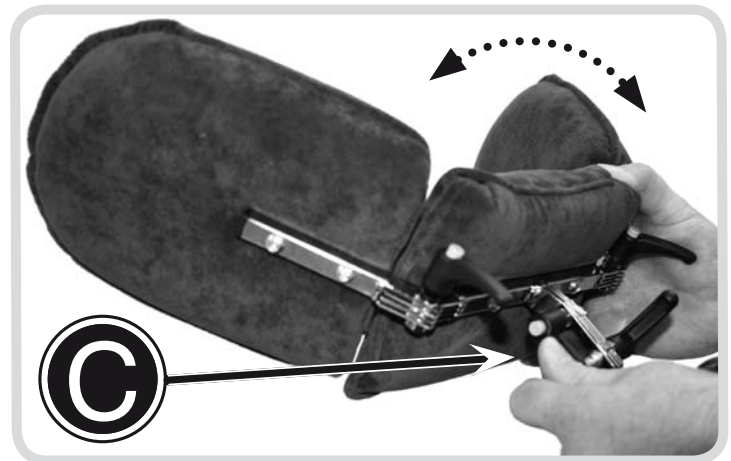
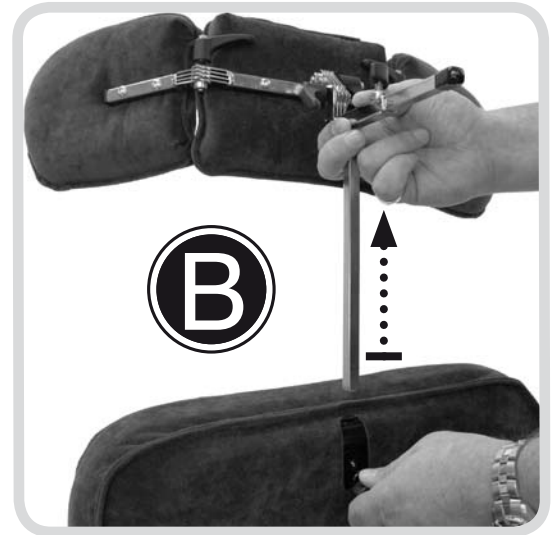

Head Support Angle

- Turn lever (C) anti-clockwise to loosen and tilt the headrest backwards or forwards. Re-tighten the lever to secure into place.

Head Support Position

- Turn lever (D) anti-clockwise to loosen and push the headrest bar backwards or forwards. Re-tighten the lever to secure into place.

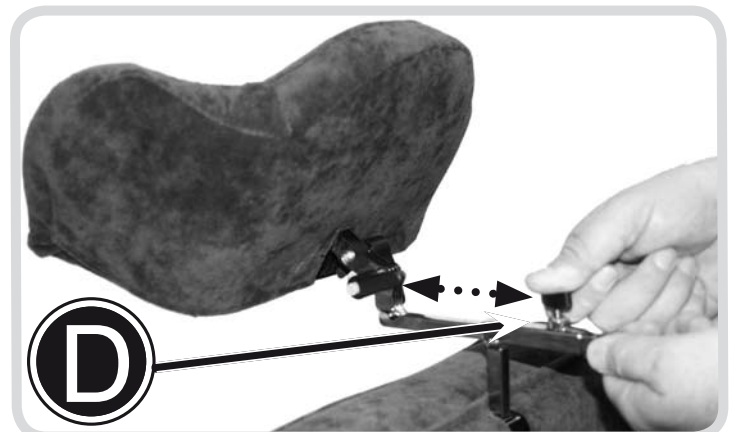

Head Support Wing Position

- Turn lever (E) anti-clockwise to loosen and push the wing support backwards or forwards until a suitable position has been found. Re-tighten the lever to secure into place.



Altering Upper Back Support

To add greater flexibility the winged back cushion can be shaped around the upper back to support any curvature in the spine and aid head support.

- Press and hold in both buttons (A) simultaneously (one either side on the frame).
- Hinge the top section of the frame (B) forward or backwards to the required position, ensuring the user has maximum back and head support.
- Once a suitable position has been found, release the buttons and the frame will lock into place.

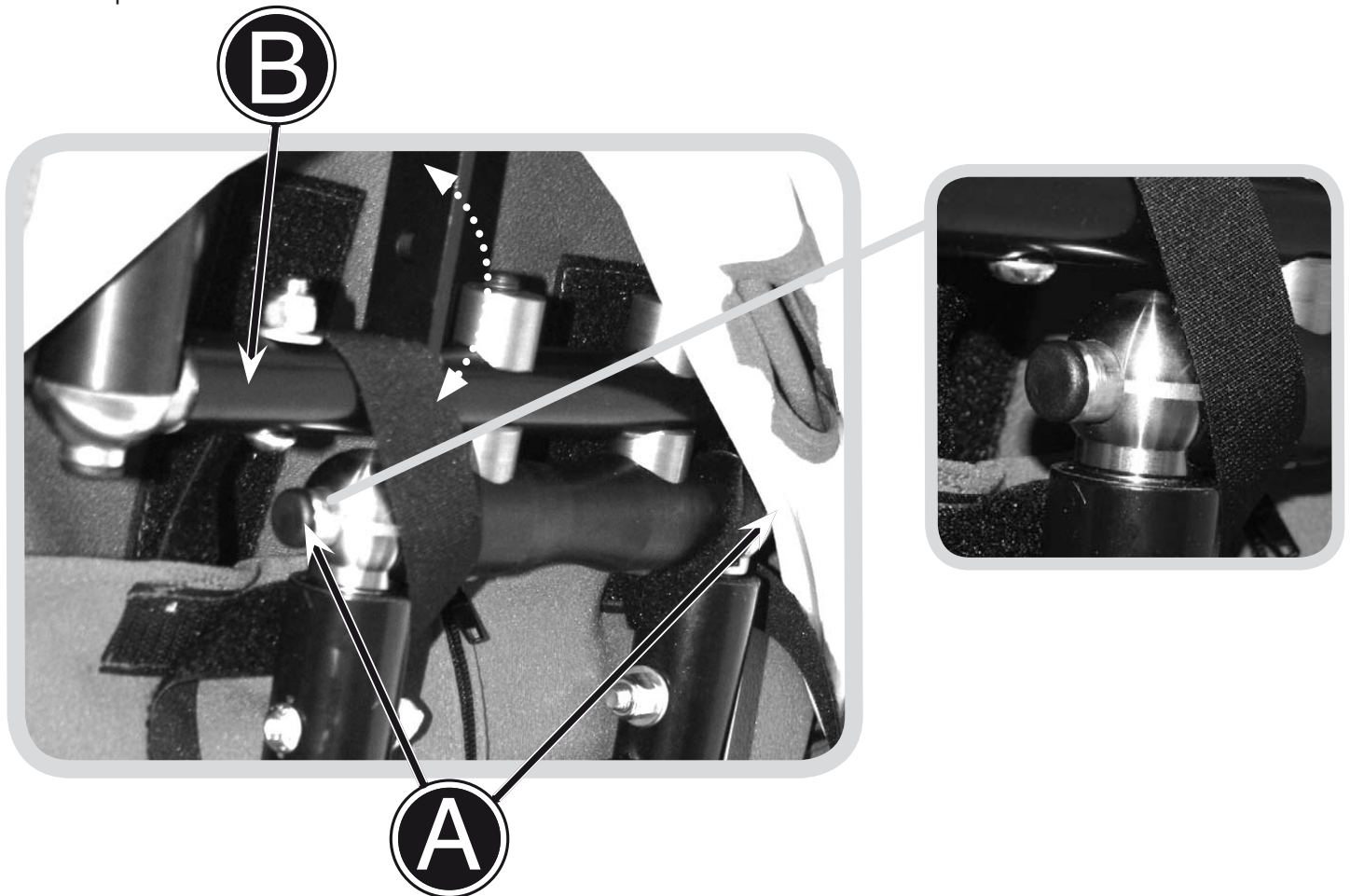

Neck Rest Use

- The neck rest is weighted at one end and simply lies over the back cushion.
- Manually adjust the weight to alter the position of the neck rest.
- The weight will ensure the neck rest stays in position.

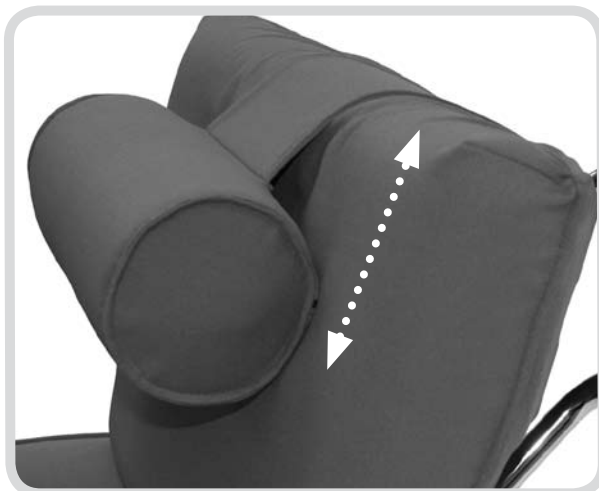

Back Height Adjustment

Back Support Height

- Pull out plungers (A) to maximum tension and turn them through a half turn anti-clockwise. This places them in an open position.
- While supporting the back, slide the top frame up or down along the bracket. The height of the back should be adjusted to fit the size of user and seat them in comfort.
- Re-locate the plungers into one of the other positions available along the frame (B).
- Turn the plungers a half turn clockwise and they should snap into a locked position to secure the frame.

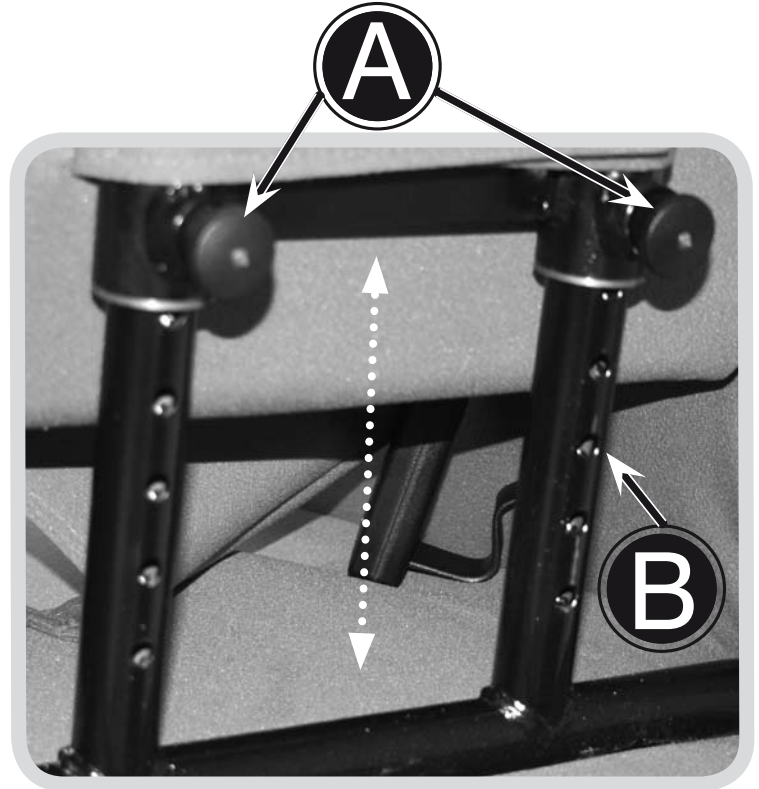

Always ensure the plungers are securely locked into place before use.

Arm Rest Adjustment / Seat Width

Arm Rest Height

- Turning lever (A) anti-clockwise enables you to adjust the height at which the armrest sits.
- Once loosened the arm can be pulled vertically upwards from the frame to raise the resting position of the armrest.
- Once a suitable position has been found the lever should be re-tightened by turning clockwise.



Arm Rest Width / Seat Width

- Un-tighten bolts (B) and (C)
- Adjust the arm by either: pulling it outwards, away from the seat frame to expand the seat width or pushing it inwards towards the frame to narrow the seat width.
- Once a suitable position has been achieved tighten screws (B) and (C) securely.

Seat Depth Adjustment



Never perform the seat depth adjustments while the user is positioned in the Jupiter 3 chair.

To allow easier access to the adjustments shown here we would recommend that the seat is positioned with the back on the floor and the seat turned upwards.

A 5mm allen key fits bolts A and B shown.

- Unscrew bolts (A) and (B) anti-clockwise until bar (C) can be moved freely.

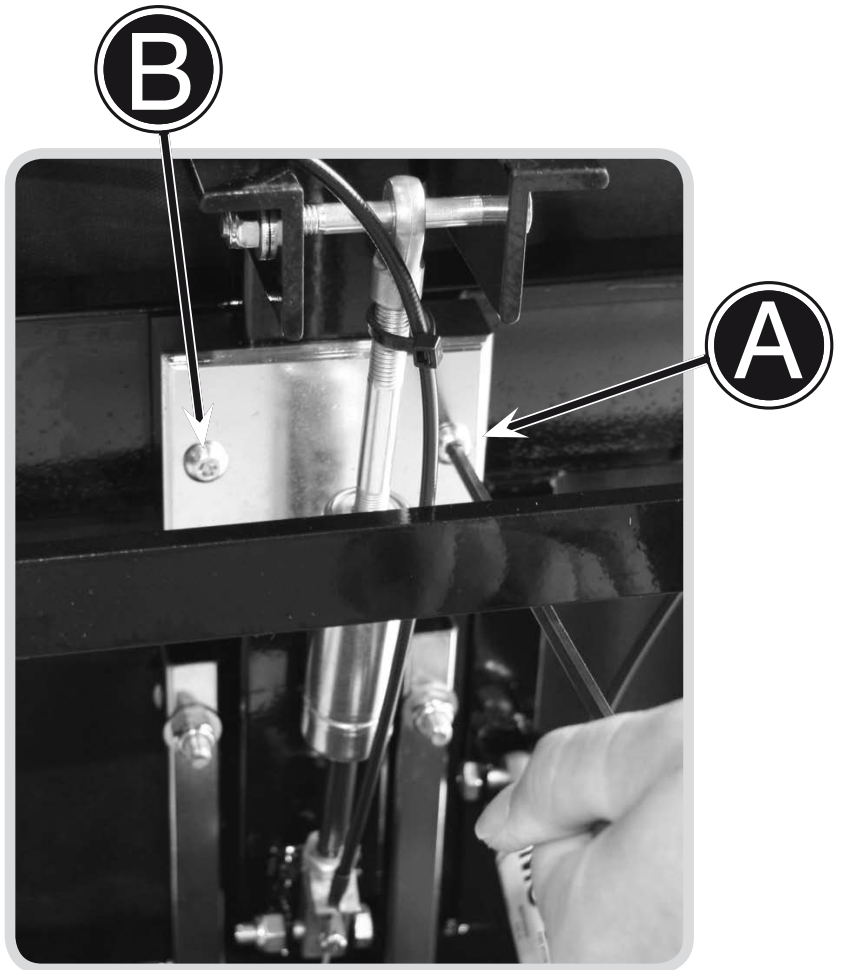

- Pull bar (C) up and away from the frame to extend or push down towards the seat frame to shorten.
- Once the required seat depth has been achieved tighten bolts (A) and (B) clockwise to lock bar (C) into position.

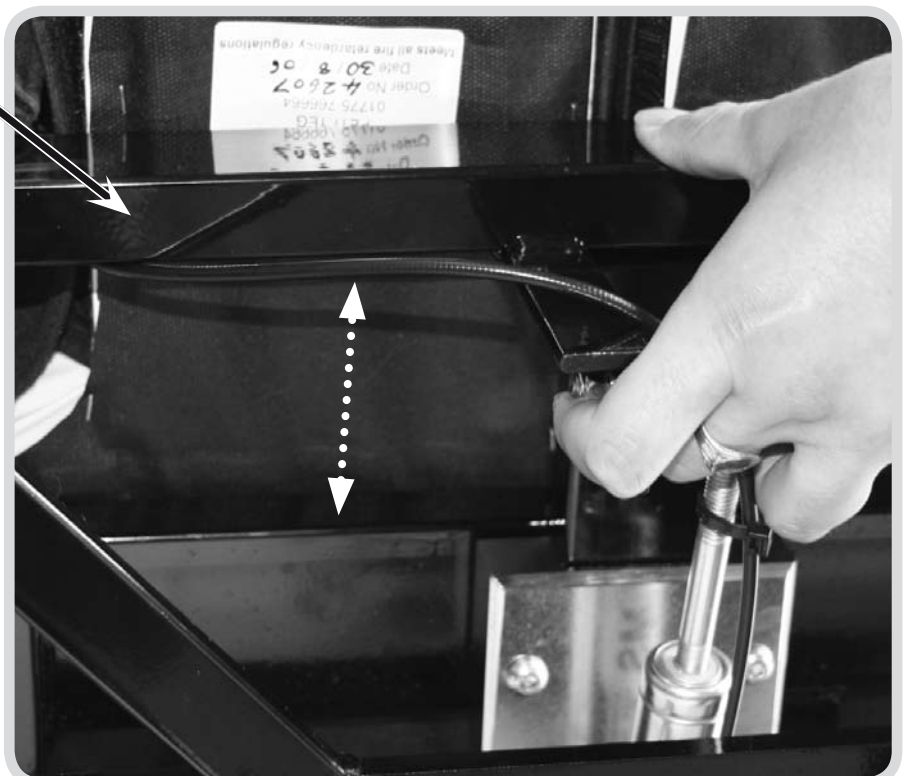

Cleaning & Care

We recommend the following points for successful cleaning of your equipment. (It is possible that some surface wrinkling may occur following these processes)

Fabric Upholstery Care

Refer to Heritage fabric cleaning guide which can be found on their website www.heritage-homecare.com

Do not use bleach, acidic, solvent, abrasive, biological or phenolic based cleaners.

Metal Framework

- If all upholstery is removed the metal framework can be cleaned with hot soapy water and detergent or it can be steam cleaned. (Labelling may need to be replaced following steam cleaning).
- Ensure that the framework is thoroughly dried after cleaning.
- Always ensure that any moving or adjustable parts are re-lubricated.

General Maintenance



General maintenance should be carried out by a competent, professional person who is well informed on how to use the equipment (see warranty - page 17) if there is no such person available or a more thorough check is needed, a service via an approved repairer (see opposite) should be booked. The person who carries out the maintenance check or service should always fill out the service history log record (page 16) in order to ensure the warranty remains valid.

As documented opposite, the degree of maintenance required is dependant on various factors relating to the use of the product. In addition to the specific functional adjustment warnings specified in this manual, it should be ensured that a thorough inspection of the following should be completed at no greater than 6 month intervals:

Castors	<ul style="list-style-type: none"> • Lift base and check each wheel to ensure it is not damaged, loose or worn.
Brakes	<ul style="list-style-type: none"> • Removing any grease or dirt that has built up on the wheels, check that the brakes stop the wheels rotating. • Check they are securely fixed in place and that there are no signs of damage or wear and tear.
Pushing Handles	<ul style="list-style-type: none"> • Ensure handles are functioning correctly. • Check there are no signs of damage or wear and tear. • Ensure push handle grips are secure.
Seat Tilt In Space Mechanism	<ul style="list-style-type: none"> • With the tilt lock released check for free movement with no signs of damage or wear to the mechanism, lever or cables. • Tighten the lock and ensure it holds the seat angle.
Seat / Backrest Upholstery	<ul style="list-style-type: none"> • Check the attachment points of the seat and backrest upholstery are tight. • Check for worn covering. Rough worn upholstery can cause discomfort, would be difficult to keep hygienically clean, & may cause skin irritation.
Frame With correct maintenance the frame should provide at least 5 years trouble free use but, depending on conditions of use, wear will occur and a thorough inspection is recommended.	<ul style="list-style-type: none"> • Check all metal parts to ensure there are no signs of damage or wear and tear, paying particular attention to adjustable or moving parts. • Check there are no signs of failure in joints and welds. • Check tightness and security of all fixings, bolts, nuts, spring loaded pegs, and other fitments. • Check for signs of fatigue wears, replace parts that show signs of wear or repeatedly becoming loose. • ANCHOR POINTS (where applicable) for transportation must be checked to ensure security, check there are no signs of damage, wear and tear or failure.
Fixtures	<ul style="list-style-type: none"> • Check arm pads and headrest and replace if worn.

Points listed here are generic across the Heritage range and do not apply to all products.

Servicing via Approved Repairer

What should be completed during a service?

A service is a comprehensive combination of inspection, maintenance and repair or replacement of worn, faulty or missing components. The growth and any changes of the occupants needs since the original assessment is taken into account when performing the service. This is in contrast to general maintenance (opposite), where only straightforward checks, inspections and adjustments take place and primary services are planned.

What happens if a fault is found?

If any faults are found that could prove to be a risk to either the user or the operator then all use of the equipment should be ceased immediately until the product has been repaired.

Who should carry out the service?

It is stressed that only a Heritage approved repairer or a person with competent training of a Class 1 medical device should carry out this work.

Any modifications must not be carried out without prior agreement of Heritage Homecare. It must be understood that unauthorised modifications may pose a risk to all users and attendants, as well as potentially invalidate the warranty.

Any new parts required should be genuine Heritage Homecare approved parts, fitted to Heritage specifications.

Frequency of Service

Heritage recommend that a service of this product is completed once every 6 months as a minimum. However, the frequency of inspection and service must be altered depending upon the severity of use. If the system is used in any of the following ways then the use could be said to be fairly heavy and constant. Therefore we would recommend the service interval be reduced to once every three months;

- Daily for around 8 to 10 hours.
- Weekly for at least 6 days out of 7.
- Monthly for at least 11 months a year.
- By an active user or somebody who is very active voluntarily or involuntarily.
- By a user who is above 80% of the maximum user weight recommended.
- Transported in a moving vehicle twice or more in a day.

If the usage exceeds the amount highlighted above it is possible that services every six weeks or less might be needed.

How To Book A Service

Heritage have specified technicians trained to service our products. If you would like Heritage to service your chair or for further information please contact us on 01733 405830.

Alternatively, contact the person who issued you with the product.

Warranty

3 YEAR WARRANTY

Products manufactured by Heritage are covered with a manufacturers 3 year warranty.

What it Covers

The warranty covers all aspects of product failure due to faulty workmanship or manufacturing.

Period of Cover

The period of the warranty runs for 3 years from the date that the product is dispatched.

The Work Heritage is Obligated to Complete

Heritage's obligation under this warranty is to replace or repair any defective goods within the period of the warranty free of charge.

What the Warranty Does Not Cover

- Items that are damaged or fail due to natural wear and tear, extreme usage, neglect or misuse.
- Accidental damage, modifications or repairs carried out by a third party unauthorized by Heritage or non professional healthcare representative.

Customer Responsibility

To ensure the warranty remains valid, customers are advised that servicing, maintenance and re-issuing guidelines must be followed and documented as stated in the manual.

Heritage will require proof of service (see opposite) for any warranty claims or orders.

When making a claim Heritage reserve the right to inspect the product and all necessary documentation.

Only valid for products purchased after 1st April 2006. Applies only to products exclusively manufactured by Heritage.



3 YEAR WARRANTY

IMPORTANT

Heritage Homecare will not be held responsible for any damage or injury caused by incorrect use of this product. For any information or guidance on the use of this product please call our office who will put you through to your local representative or send you any additional information you may require.

Tel: 01733 405830

Inspecting & Reissuing of Equipment

Most Heritage Homecare products are individually assessed for a client prior to issue. They are handed over in a controlled way to ensure optimum fit and specification, checks are completed and any additional individual verbal instructions given. We therefore recommend the following points are adhered to prior to any re-issue of equipment:

- **Cleaning**

Follow a rigorous process of cleaning in order to decontaminate the product and eliminate the chance of cross infection.

- **Assessment of Fabrics / Foams**

Carefully assess the condition of fabrics and foams in the seating product, and have these replaced partially or even completely if need be. In severe cases if the chassis is worn and the seating in poor condition it may be necessary to have the product re-furnished by the manufacturer. In very severe cases if the chassis is badly worn and the seating in very poor condition then the product should be decommissioned and disposed of.

- **Electrical and Electronic Equipment Decommissioning**

If your product is set up with an electrical function you should always contact Heritage or your authorised representative for de-commissioning information.

- **Appropriateness of Equipment**

Check that the equipment supplied is appropriate for the needs of the user taking age, weight, ability, diagnosis, and any other important factors into account. For instance, Heritage Homecare products may not be suitable for persons with severe challenging patterns of behaviour. Also ensure safe specified limits for use are not exceeded by the new user. Your sales representative can advise on the suitability of the equipment.

- **Manuals and Records**

Ensure this instruction manual and any additional manuals for the seating unit are handed over to the new user with the equipment and ensure the servicing log history is up to date. Records on the new user must be updated to maintain traceability.

- **Inspection**

The equipment should have a rigorous inspection prior to the reissue, to include the points covered in the six monthly routine check, regardless of if the checks were recently completed. The equipment should be free of excessive wear or distortion in any aspect of its main construction or accessories.

- **Condition**

Wheels, tyres and brakes must be in good working condition, properly adjusted and inflated as appropriate.

- **Accessories**

Check all accessories carefully for damage and potential shortcomings which may pose a risk to the user.

- **Function**

Ensure that all the functions of the chair are working correctly e.g. tilt in space, height adjustment, back recline, folding etc.

- **Fixings**

Check that any knobs, hand wheels, nuts, bolts, levers and fixings are in good condition and fitted in place securely.

- **Modifications**

Any special modifications, adaptations, alterations or other such procedures including added accessories may require review. If they are found inappropriate, remedial action (if considered safe and practical) should be taken to reverse them if possible.

- **Labelling**

Any labelling specific to the previous user should be removed and replaced with labelling specific to the new user.

- **Adjustment**

Adjustment of the equipment to the new user must be carried out by suitably qualified and experienced professionals. These adjustments along with the other appropriate checks and tests should be completed with the owners knowledge and agreement.

















- **Hand Over**

Competent handing over of the equipment to the new user or attendant must include proper training and advice in safe use, particularly regarding transportation issues.

- **Packaging**

Always ensure that the chair is packaged correctly before delivery.

TABLE OF SYMBOLS

Symbol	Meaning
	Manufacturer
	Max occupancy weight
	Serial number
	Product code
	Read the Instructions for Use
	CE mark
	UKCA mark
	Medical Device
	Warning
	Date of Manufacture
	Latex free
	Unique Device Identification
	Machine wash- water temperature 40°C
	Do not bleach
	Do not tumble-dry
	Do not iron
	Do not dry-clean

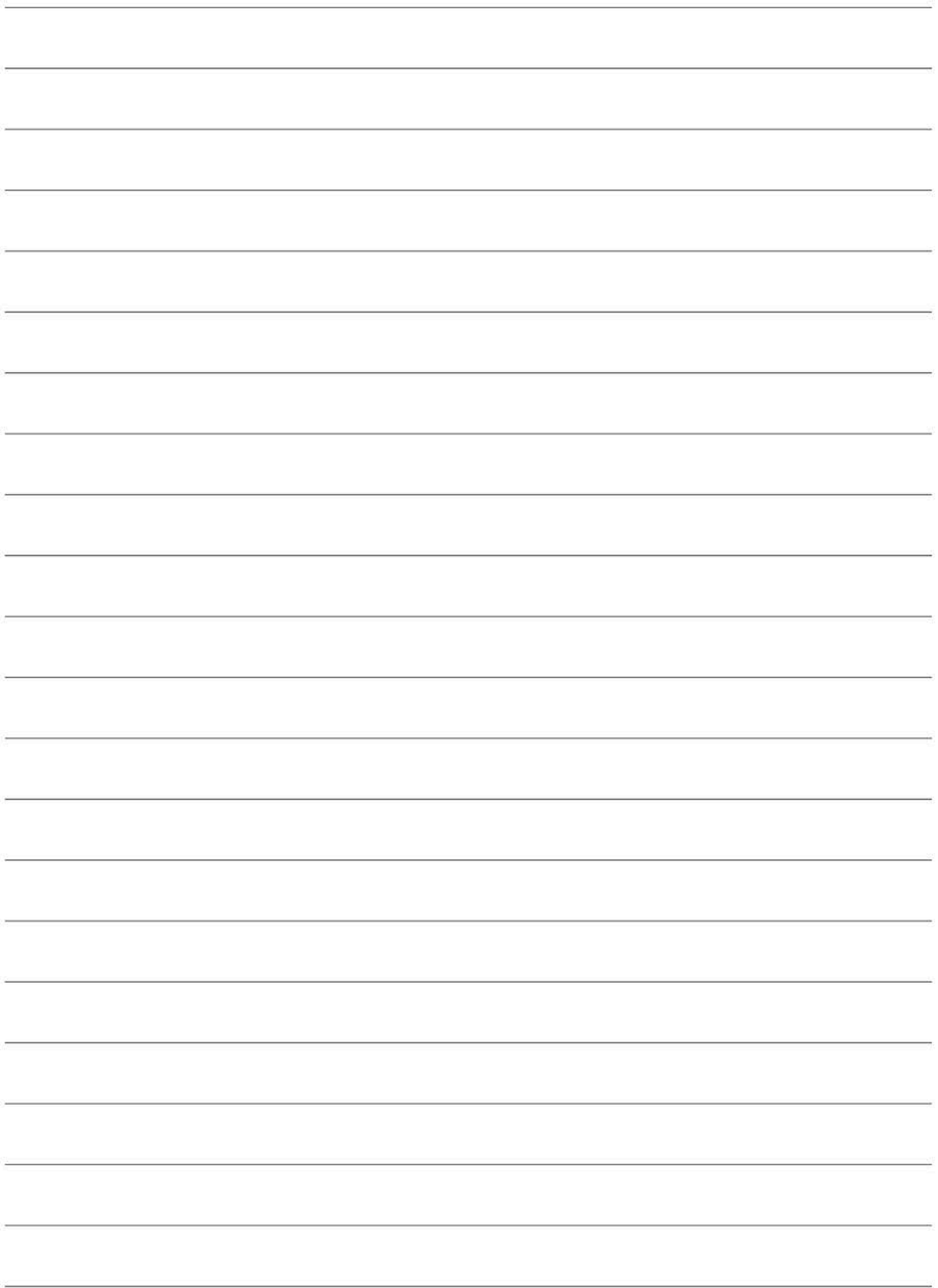

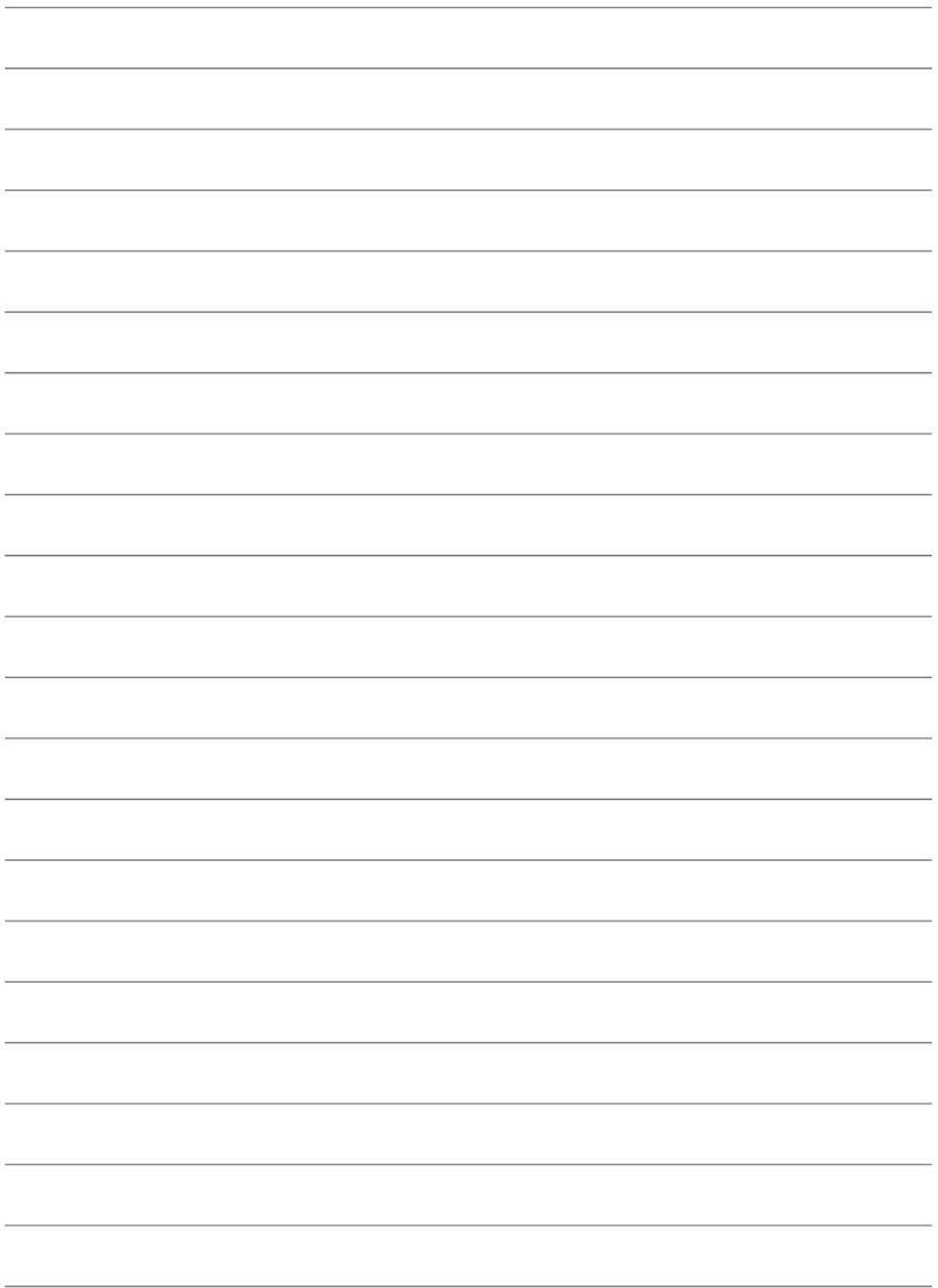



Heritage

design for living

USA Distributor

Sunrise Medical (US) LLC
2842 N Business Park Avenue
Fresno, CA 93727

T: 1-800-333-4000
F: 1-800-300-7502
E: customseating@sunmed.com

sunrisemedical.com

Canadian Distributor

Sunrise Medical
237 Romina Drive, Unit 3,
Concord, ON, L4K 4V3
sunrisemedical.ca

T: +1.800.263.3390
F: +1.800.561.5834
E: mkt.canada@sunmed.com

15 -18 Maxwell Road,
Woodston Industrial Estate, Peterborough,
Cambridgeshire
PE2 7HU

Tel: 01733 405830
Fax: 01733 405838
Email: enquiries@heritage-homecare.com

**UK
CA**



INVESTOR IN PEOPLE

